



# Determination of organochlorine pesticides in water using microwave assisted headspace solid-phase microextraction and gas chromatography

Hong-Ping Li<sup>a,b</sup>, Gwo-Chen Li<sup>b</sup>, Jen-Fon Jen<sup>a,\*</sup>

<sup>a</sup>Department of Chemistry, National Chung-Hsing University, Taichung 402, Taiwan

<sup>b</sup>Residue Control Department, Taiwan Agricultural Chemicals and Toxic Substances Research Institute, Council of Agriculture (TACTRI/COA), Wu-Feng, Taichung Hsien 413, Taiwan

Received 20 September 2002; received in revised form 15 May 2003; accepted 19 May 2003

## Abstract

A coupled technique, microwave-assisted headspace solid-phase microextraction (MA-HS-SPME), was investigated for one-step in situ sample pretreatment for organochlorine pesticides (OCPs) prior to gas chromatographic determination. The OCPs, aldrin, *o,p'*-DDE, *p,p'*-DDE, *o,p'*-DDT, *p,p'*-DDT, dieldrin,  $\alpha$ -endosulfan,  $\beta$ -endosulfan, endosulfan sulfate, endrin,  $\delta$ -HCH,  $\gamma$ -HCH, heptachlor, heptachlor epoxide, methoxychlor and trifluralin were collected by the proposed method and analyzed by gas chromatography with electron-capture detection (GC-ECD). To perform the MA-HS-SPME, six types of SPME fibers were examined and compared. The parameters affecting the efficiency in MA-HS-SPME process such as sampling time and temperature, microwave irradiation power, desorption temperature and time were studied to obtain the optimal conditions. The method was developed using spiked water samples such as field water and with 0.05% humic acid in a concentration range of 0.05–2.5  $\mu\text{g}/\text{l}$  except endosulfan sulfate in 0.25–2.5  $\mu\text{g}/\text{l}$ . The detection was linear over the studied concentration range with  $r^2 > 0.9978$ . The detection limits varied from 0.002 to 0.070  $\mu\text{g}/\text{l}$  based on  $S/N=3$  and the relative standard deviations for repeatability were  $< 15\%$ . A certified reference sample of OCPs in aqueous solution was analyzed by the proposed method and compared with the conventional liquid-liquid extraction procedure. These results are in good agreement. The results indicate that the proposed method provides a very simple, fast, and solvent-free procedure to achieve sample pretreatment prior to the trace-level screening determination of organochloride pesticides by gas chromatography. © 2003 Published by Elsevier B.V.

**Keywords:** Solid-phase microextraction; Microwave assisted extraction; Headspace analysis; Extraction methods; Water analysis; Organochlorine compounds; Pesticides

## 1. Introduction

Organochlorine pesticides (OCPs) such as aldrin,

benzene hexachloride ( $\gamma$ -BHC), heptachlor, and DDT were heavily used from the 1950s through to the 1970s and were finally phased out of use in Taiwan in 1973 due to toxic effects on wildlife. These compounds are resistant to degradation in the environment and have a tendency to bioaccumulate in animals [1]. Their residues still widely remain in

\*Corresponding author. Tel.: +886-4-2285-3148; fax: +886-4-2286-2547.

E-mail address: [jjfjen@dragon.nchu.edu.tw](mailto:jjfjen@dragon.nchu.edu.tw) (J.-F. Jen).

the environment at this time. In most cases, residue levels are rather low, mostly within the ppb range [2]. Therefore, a rapid, convenient, accurate, and sensitive method is required to monitor their concentrations in river water, soil sediments and biotic samples.

Chromatographic techniques have been considered as the best methods to determine OCPs in varied sample matrices. Before the chromatographic measurement, appropriate sample pretreatments are generally required to clean up or preconcentrate the target species. Previous studies have set forth various extraction techniques for OCPs in water, including liquid–liquid extraction (LLE) [3] and solid-phase extraction (SPE) [4,5] for semivolatile and non-volatile compounds or headspace extraction [6] and purge-and trap (P and T) [7] for volatiles. Although these conventional extraction methods offer efficient and precise results, they are relatively time-consuming, hazardous to health due to the usage of organic solvents, and highly expensive with respect to the disposal of solvents [8]. In recent years, much effort has been directed towards reducing laboratory-generated wastes while improving detection limits at the same time. Pawliszyn et al. [9–12] first invented the solvent-free extraction method, solid-phase microextraction (SPME), to analyze organic pollutants in water samples. This invention resolves part of the problems. For the determination of OCPs in water sample, Aguilar et al. [13] optimized the immersion SPME conditions for OCPs, Goncalves and Alpendurada [14,15] compared the extraction efficiency of fibers for the analysis of pesticide multiresidues based on the structure. Tomkins and Barnard [16] determined 19 OCPs using 30- $\mu\text{m}$  poly(dimethylsiloxane) PDMS fiber for extraction. They obtained satisfactory results with SPME pretreatment. However, the extraction recovery of organic pollutants by SPME was found to be significantly influenced by the complex sample matrix [17]. Therefore, headspace SPME (HS-SPME) was developed and applied successfully to avoid the matrix effects [18–20]. Doong and Liao [21] took 20–220 min to collect 18 OCPs and their metabolites in soil samples with HS-SPME. The findings indicate that the HS-SPME sampling is only suited for volatile analytes, or it will take a long time to finish the sampling having moderate sensitivity and reproducibility. Thus, the

headspace sampling technique is limited to volatile and semivolatile organic compounds.

In this decade, microwave-energy was investigated and widely applied in analytical chemistry such as accelerating sample digestion, extraction, and also in chemical reactions [22–24]. In general, microwave-assisted extraction (MAE) achieves a 90% reduction in solvent consumption [25,26]. Through the dipole rotation and ionic conductance of polar substances or ionic species under the microwave irradiation, the temperature of the system rises rapidly. Therefore, microwave heating has the potential to improve the SPME sampling for organic compounds. Associating SPME with MAE or microwave-assisted distillation (MAD), two-step procedures, i.e. immersion of fibers into the aqueous solution followed by the MAE or MAD, were applied to isolate analytes from samples [27–30].

With the described advantages of HS-SPME and MAE, we have first proposed a MA–HS-SPME system to achieve the one-step in situ headspace sampling prior to chromatographic determination [31,32]. In the present study, the MA–HS-SPME was investigated to collect OCPs on SPME fiber from water sample. The MA–HS-SPME technique coupled to GC–electron capture detection (ECD) is systematically investigated to develop a simple, fast, and solvent-free analytical process for the determination of OCPs in water.

## 2. Experimental

### 2.1. Chemicals and reagents

Deionized water was produced using a Milli-Q water purification system from Millipore (Bedford, MA, USA) for all aqueous solutions. All chemicals and solvents were of ACS reagent grade. Pesticides, analytical-standards grade from Dr. Ehrenstorfer com. and Riedel-de H  en (Hannover, Germany), were used without further purification (purity was >95% for all pesticides). *n*-Hexane was obtained from Merck for preparing standard stock solutions. Individual solutions of 1000 mg/l of each pesticide (aldrin, dieldrin, *o,p'*-DDE, *p,p'*-DDE, *o,p'*-DDT, *p,p'*-DDT,  $\alpha$ -endosulfan,  $\beta$ -endosulfan, endosulfan sulfate, endrin,  $\delta$ -HCH,  $\gamma$ -HCH, heptachlor, hepta-

chlor epoxide, methoxychlor, trifluralin) were prepared in *n*-hexane. Their standard stock solutions of 0.01 mg/l were prepared in *n*-hexane and stored in silanized brown glass bottles with PTFE-lined cap, and kept at 4 °C. Sodium chloride and sodium hydroxide were obtained from Riedel-de Häen. Hydrochloric acid (36.4%) was from J.T. Baker (Phillipsburg, USA). The certified reference sample (CRM) of aqueous OCPs was obtained from APG (Analytical Products Group). The high purity nitrogen gas (99.999%) for GC carrier gas was obtained from a local supplier (Lien-Hwa, Taichung, Taiwan).

## 2.2. GC–ECD system

The GC used in this work was a Hewlett-Packard 6890 (Agilent Technologies) equipped with a split/splitless injector and an electron capture detector (ECD,<sup>63</sup>Ni). Separations were done through a fused-silica DB-608 capillary column (30 m×0.25 mm I.D., 0.25 μm film thickness; Agilent Technologies). Nitrogen was used as the carrier gas at a constant flow-rate (1 ml/min). The detector and injector temperatures were held constant at 300 and 310 °C, respectively. The oven temperature was programmed as follows: 150 °C, 20 °C/min to 230 °C (2.0 min), 20 °C/min to 260 °C with a final hold for 7.5 min.

## 2.3. Microwave-assisted solid-phase microextraction

The microwave oven used in this work was a modified version of the home-used Sunhow SH-1100 system (2450 MHz, Taiwan) with a maximum power of 700 W, equipped with a cooling system (YIH DER BL-720, Taiwan). A microwave stirrer (cat. no. 37040-0000 from Scienceware, Bel-Art Products, USA) was used for stirring the samples at 300 rpm during extraction. The sampling system was set-up as shown in Fig. 1. In order to contain microwave irradiation, aluminum foil was tacked on the inner-wall and the outer-wall of microwave body in the interface part. A microwave leak detector (MD-2000, Less EMF, NY, USA) was used to check the safety aspects before the run.

The SPME device consisted of a holder (Supelco 57331) and fiber assembly for manual sampling was obtained from Supelco (Bellefonte, PA, USA) and

used without modification. Six types of fibers, PDMS (100 and 30 μm), CW–DVB (Carbowax–divinylbenzene, 65 μm), PDMS–DVB (polydimethylsiloxane–divinylbenzene, 65 μm), DVB–CAR–PDMS (CAR=Carboxen) (50 and 30 μm), CAR–PDMS (75 μm) and PA (polyacrylate, 85 μm) from Supelco were used. Fibers were initially conditioned according to the manufacturer's instructions. The needle on the SPME manual holder was set at its maximum length of 4 cm in the GC injector port. A desorption temperature of 310 °C for 3 min was set to produce the highest sensitivity of OCPs. All the analyses were performed with a 50-ml glass round bottle containing 20 ml of sample solution. To each sample, 2 g of sodium chloride was added. The flask was connected an 11-ml Y type glass tube having been silanized to the microwave. The arm of Y type glass tube was connected to a water condenser (Fig. 1). The SPME fiber was exposed to the headspace in the Y type glass tube with 80% power irradiation of microwave for 10 min. The sample was agitated with a magnetic stirring bar at 300 rpm during the extraction process. After sample collection, the SPME fiber was withdrawn from the headspace and inserted immediately into the GC injector port for thermal desorption. The SPME conditions used for method validation were as follows: 12 min of the different fibers kept in the headspace during stirring the solution (20 ml, 300 rpm) at 80% power (285 W) of microwave irradiation and 3 min in the GC injector (split mode, split ratio 10:1) at 310 °C for thermal desorption.

## 2.4. Liquid–liquid extraction (LLE) [33]

A water sample (20 ml) was added into flask containing 20 ml acetone, and then 5 ml 10% NaCl solution and 15 ml of petroleum ether were added, prior to extraction with 25 ml methylene chloride twice. Both organic layers were combined and dehydrated with ~20 g of anhydrous Na<sub>2</sub>SO<sub>4</sub>. The anhydrous organic phase was evaporated to near dryness with a vacuum rotary evaporator. The residue was dissolved with *n*-hexane and the volume was adjusted to 2 ml exactly. This portion of the sample solution was used to clean up.

A sample solution (1.0 ml) was taken and cleaned up through a Florisil SPE cartridge (1000 mg/6 ml)

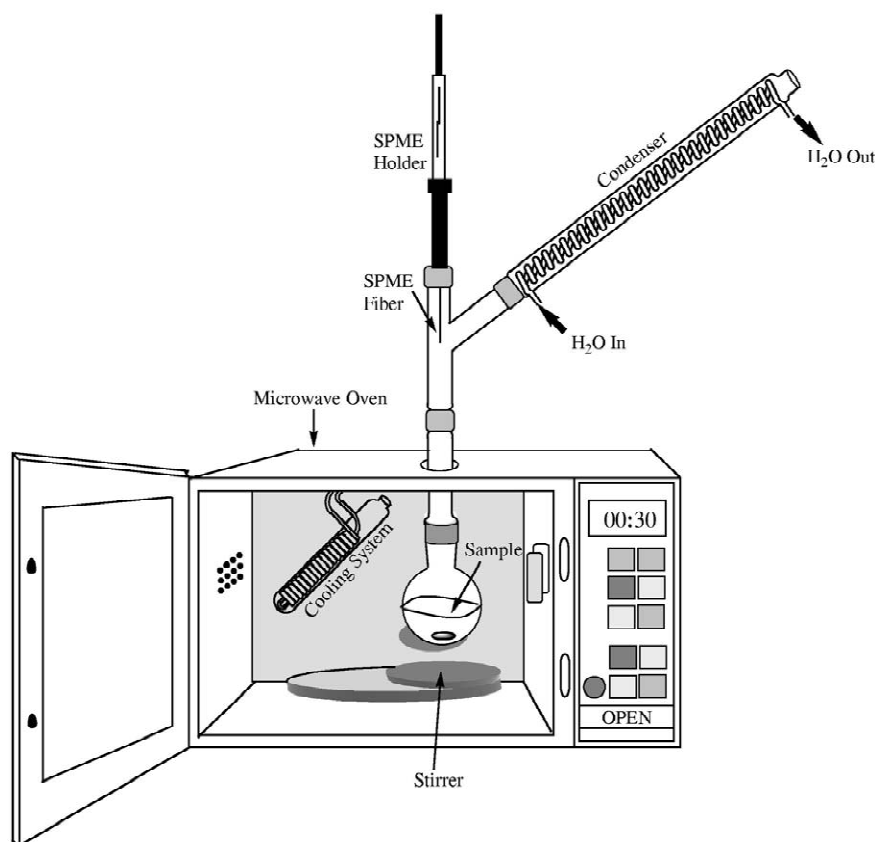

Fig. 1. Assembly of the MA-HS-SPME apparatus.

with the procedure as follows: The Florisil SPE cartridge was preconditioned first with 10 ml *n*-hexane prior to the concentration step; after pre-concentrating the sample solution (in hexane), the sample species retained in the cartridge was eluted with 15 ml *n*-hexane–methylene chloride (1:5, v/v) and collected. The collection was purged with N<sub>2</sub> to dryness and the residue redissolved with 1.0 ml *n*-hexane. This fraction of the sample solution was used for the determination of organochlorine pesticides by GC–ECD.

### 3. Results and discussion

#### 3.1. Optimization of MA-HS-SPME procedure

In order to optimize the MA-HS-SPME sampling technique for OCP analysis, parameters affecting the

sampling efficiency, such as selection of SPME fiber coating, microwave irradiation power, headspace volume, extraction time, and desorption conditions (temperature and time) were studied and optimized.

##### 3.1.1. Selection of SPME fiber coating

The chemical properties of target analytes (polarity, volatility, water solubility, or molecular mass) determine the type of a fiber coating used. In order to select an appropriate coating for the MAE-HS-SPME sampling, six commercial SPME fiber-coatings were evaluated. A fortified aqueous sample (20 ml spiked with 0.5 μg/l of each OCPs) was analyzed in triplicate with each fiber. The results after 10 min MAE-HS-SPME sampling at 80% power irradiation and GC–ECD determination are shown in Fig. 2. The mixed DVB–CAR–PDMS fiber has the highest absorption capacity for nine OCPs (aldrin, *o,p'*-DDE, α-endosulfan, endosulfan sulfate, δ-HCH, γ-

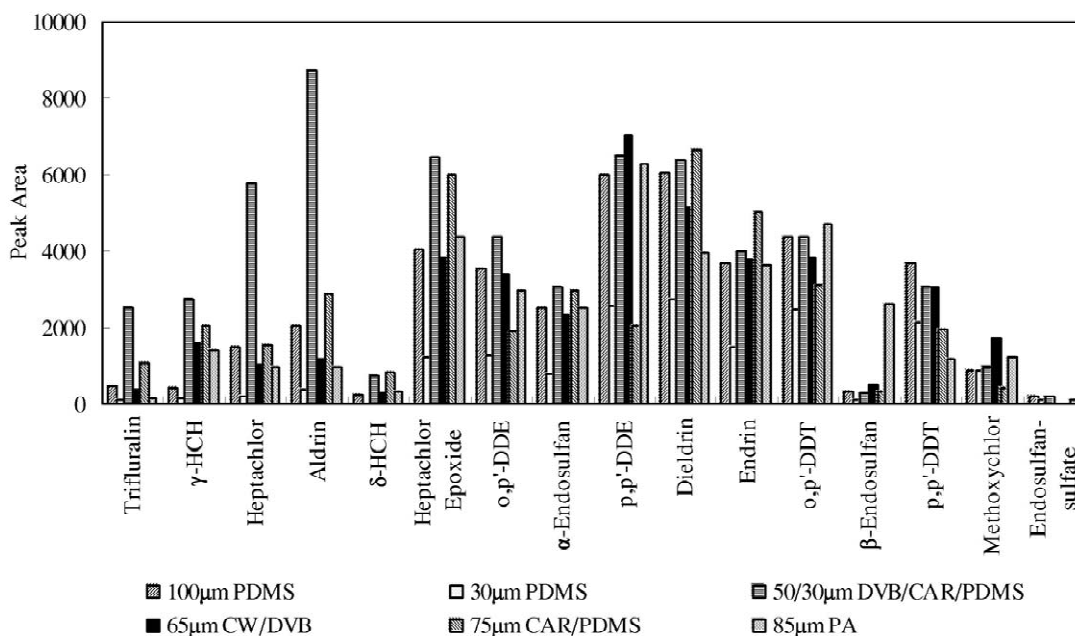

Fig. 2. Relative extraction efficiency of various fiber coatings for sampling OCPs. The relative extraction efficiencies represented graphically as average peak areas (y axis) obtained for each OCP (20 ml water containing 0.01  $\mu\text{g}$  each OCP).

HCH, heptachlor, heptachlor epoxide, trifluralin), it also has relatively high collection efficiency for *p,p'*-DDE, dieldrin, endrin, *o,p'*-DDT, and *p,p'*-DDT. The porous carbon adsorbent (Carboxen) and porous polymer (divinylbenzene) in the mixed DVB–CAR–PDMS fiber coating offer strong attraction forces to these bipolar compounds. Besides, the CWX–DVB and PA polar fibers are also suitable for collecting *p,p'*-DDE, dieldrin, endrin, *o,p'*-DDT,  $\beta$ -endosulfan, *p,p'*-DDT, and methoxychlor with a relatively high extraction efficiency due to the polarity and high surface area of the fiber. As to the PDMS fiber (a nonpolar phase), it has an acceptable level for collecting *p,p'*-DDE, dieldrin, endrin, *o,p'*-DDT, *p,p'*-DDT, heptachlor, and *o,p'*-DDE. The CAR–PDMS fiber can be used to collect dieldrin, endrin, heptachlor epoxide and  $\alpha$ -endosulfan. Thus, considering the extraction efficiencies for all 16 OCPs, the mixed DVB–CAR–PDMS fiber is recommended and was used in the studies.

### 3.1.2. Effect of headspace volume

The volume of the headspace should be minimized for a high-efficiency headspace extraction [34]. In our studies, headspace volumes of 32 and 11 ml

were evaluated. Results indicate that when the headspace volume decreased from 32 to 11 ml, the chromatographic peak areas increased by 135–392% for the OCPs except trifluralin, heptachlor and aldrin which were <100%. Because 11 ml is the minimal headspace volume we can obtain in the MA–HS–SPME apparatus, this volume was used through the studies.

### 3.1.3. Optimization of microwave irradiation conditions

In this study, MA–HS–SPME was employed for directly collecting the OCPs from an aqueous sample. The parameters affecting the heating, including microwave irradiation power and irradiation time, are investigated. From the recovery studies of OCPs on DVB–CAR–PDMS fiber during various irradiation powers (10 min sampling), the 80% power (285 W) gave better extraction than the others, especially for the lower boiling point compounds (aldrin, dieldrin, *o,p'*-DDE, *p,p'*-DDE, *o,p'*-DDT,  $\alpha$ -endosulfan, endosulfan sulfate, endrin,  $\delta$ -HCH,  $\gamma$ -HCH, heptachlor, heptachlor epoxide, trifluralin). The recoveries of OCPs on the DVB–CAR–PDMS fiber at various irradiation times at 80% power, increase with

time reaching the optimum at 10 min, and then decrease. This indicates that the OCPs might be lost due to their volatility with longer microwave irradiation. Therefore, microwave irradiation with 80% irradiation power for 10 min was chosen.

### 3.2. Thermal desorption temperature and time in GC injection port

In general, desorption at a higher temperature or a long time is required to ensure complete desorption of the analytes from the fiber. However, for better separation efficiency, thermal desorption requires a possible minimum time. The OCPs have a wide range of boiling points and are unstable at high temperature and, hence, the optimal desorption temperature and desorption time in a hot GC injector were investigated to obtain an acceptable result. Results indicate that 3 min is enough at 310 °C desorption. After this period no significant blank values were observed in the carryover tests. Thus, no further regeneration mode for the fiber was necessary, and a total of 3 min is required for each run of thermal desorption.

### 3.3. Calibration plot, detection limit and repeatability

In order to test the applicability of the proposed MA–HS–SPME–GC–ECD method for the quantitative determination of OCPs, standard solutions were used for calibration after they were subjected to the overall treatment procedure, i.e. MA–HS–SPME and thermal desorption from the fiber into the chromatographic system. An ECD chromatogram of OCPs standards is shown in Fig. 3a. Calibration plots were built-up over the concentration range of 0.05–2.5 µg/l to have good linearity with a correlation coefficient better than 0.9978. The detection limits varied from 0.002 to 0.070 µg/l based on three times the average background noise divided by the detection sensitivity (slope of calibration plot).

The precision of this method was estimated by performing eight extractions of sample solutions spiked with all the studied OCPs at concentrations given in the Experimental section. The precisions (RSD values) ranged between 3.5 and 16.5%, which

should be satisfactory for determining the OCPs in field water.

### 3.4. Matrix effect

In order to investigate the matrix effect in humic-rich water and real field water samples, fortified aqueous samples (20 ml humic-rich water and field water spiked at 0.5 µg/l of each OCPs) were analyzed three times with the proposed procedure. Chromatograms of the spiked water samples are shown in Fig. 3b and c. The chromatograms were not interfered with by the matrix through the MA–HS–SPME pretreatment. The peaks still kept their good resolution. Table 1 lists the recoveries (relative to those in pure water) and precision of 16 OCPs in humic-rich water and in field water. Only the DDT (*o,p'*-DDT and *p,p'*-DDT) and its metabolites (*o,p'*-DDE and *p,p'*-DDE) as well as the aldrin were significantly influenced by humic matters. The recoveries ranged from 68.8 to 118.0%. As for the recovery in field water samples, all 16 OCPs except the  $\alpha$ -endosulfan,  $\beta$ -endosulfan and  $\delta$ -HCH showed a satisfactory recovery. The reasons for the unexpectedly low recoveries of the  $\alpha$ -endosulfan,  $\beta$ -endosulfan and  $\delta$ -HCH in the field water matrix require further investigation.

### 3.5. Analysis of certified reference material (CRM) aqueous sample

In order to validate the MA–HS–SPME procedure for determining the OCPs in aqueous samples, a CRM aqueous sample containing  $\gamma$ -HCH, heptachlor, dieldrin, endrin, and *p,p'*-DDT was tested. Due to the high concentrations of OCPs in the aqueous CRM sample, 2.0 ml of CRM was diluted with field water to get a total volume of 20 ml. The results from the MA–HS–SPME and GC–ECD analysis are listed in Table 2, and compared with that by LLE. The mean values obtained by LLE and certified values ranges of OCPs in CRM sample are also given. The results obtained with MA–HS–SPME generally agreed with those obtained by LLE, indicating that MA–HS–SPME can be considered as an alternative pretreatment step for the determination of OCPs in environmental waters.



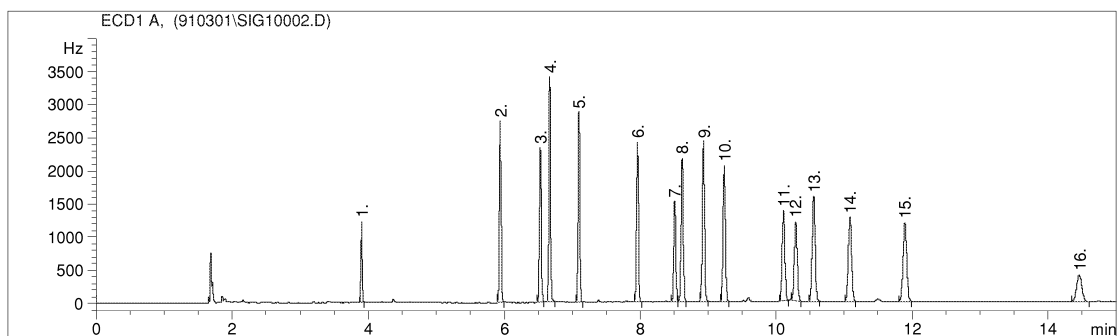

( a ) Chromatogram for standards ( 0.5ng, direct injection to GC )

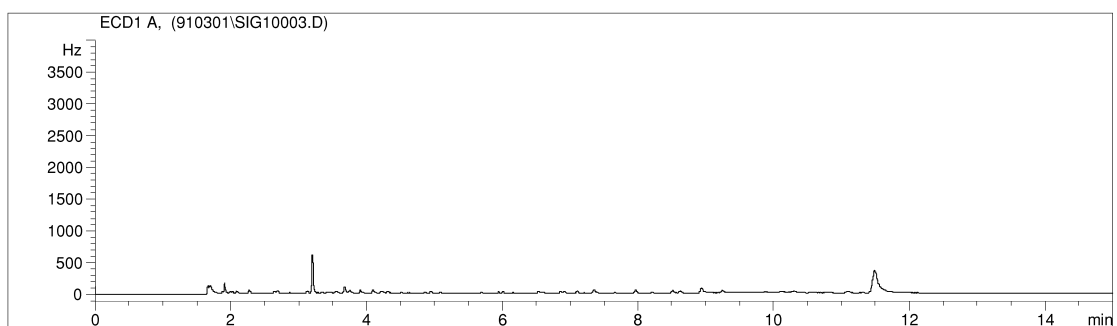

( b ) Blank water sample chromatogram ( MAE-HS-SPME method )

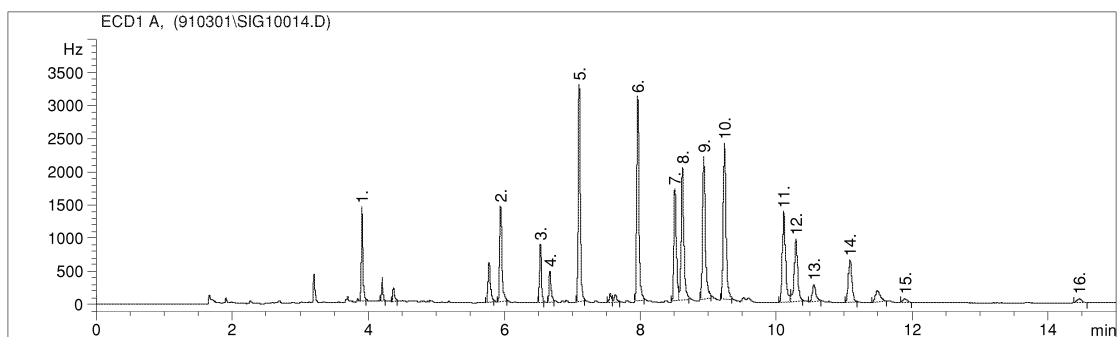

( c ) Chromatogram for spiked water sample ( 0.01 $\mu$ g OCPs spiked )

Fig. 3. Chromatograms of aqueous OCPs by GC–ECD after MAE–HS–SPME over spiked water samples. (a) Standard sample of 0.5  $\mu$ g/l OCPs pesticides. (b) Blank water sample with MAE–HS–SPME. (c) Spiked water sample (0.01  $\mu$ g OCPs spiked). Peaks: 1=trifluralin; 2= $\gamma$ -HCH; 3=heptachlor; 4= $\delta$ -HCH; 5=aldrin; 6=heptachlor epoxide; 7=*o,p'*-DDE; 8= $\alpha$ -endosulfan; 9=*p,p'*-DDE; 10=dieldrin; 11=endrin; 12=*o,p'*-DDT; 13= $\beta$ -endosulfan; 14=*p,p'*-DDT; 15=endosulfan sulfate; 16=methoxychlor.

Table 1

Recovery and precision for OCPs with the proposed MA–HS-SPME method for spiking 0.5 µg/l OCPs each in field water and in 0.05% humic acid water

Pesticides	Spiked in 0.05% humic acid water		Spiked in field water	
	Recovery <sup>a</sup> (%)	RSD (%) (n=3)	Recovery <sup>a</sup> (%)	RSD (%) (n=3)
Trifluralin	95.5	9.2	98.2	6.0
γ-HCH	98.5	5.7	98.1	4.6
Heptachlor	81.5	12.3	97.8	16.5
δ-HCH	110.2	12.7	39.0	5.5
Aldrin	68.8	13.3	85.0	1.9
Heptachlor epoxide	87.0	14.3	92.0	6.1
<i>o,p'</i> -DDE	83.9	7.6	105.0	6.1
α-Endosulfan	85.8	11.1	61.0	6.6
<i>p,p'</i> -DDE	76.5	6.5	109.0	4.4
Dieldrin	95.2	11.1	97.0	3.5
Endrin	98.7	8.7	92.9	15.3
<i>o,p'</i> -DDT	70.6	5.2	98.0	11.4
β-Endosulfan	100.3	3.6	50.0	5.7
<i>p,p'</i> -DDT	68.9	4.1	95.0	15.5
Endosulfan sulfate	118.0	13.3	108	4.1
Methoxychlor	93.7	3.2	110	13.5

<sup>a</sup> The relative recovery of pesticide to that in pure water.

### 3.6. Comparison of the proposed MA–HS-SPME method with other SPME methods

All the SPME methods have the advantage of being fast, low-cost and solving the organic solvent problems in sample pretreatment. The conventional immersed SPME is solvent-less and usually takes 30–60 min to achieve a sampling, but it suffers from matrix effects in complex samples. Although the HS-SPME method is free of matrix effect, it is limited to volatile species and takes several hours to collect less volatile species. As described previously, the MA–HS-SPME is proposed in order to shorten the sampling time of less volatile species. It takes only 10 min to complete a sample pretreatment for

OCPs. With the proposed method, the SPME fiber can be used for over 100 samplings.

## 4. Conclusions

This paper describes the determination of OCPs pesticide residuals by the proposed MA–HS-SPME–GC–ECD system, and the optimal conditions have been established. The results have proven the applicability of the proposed method to analyzing OCPs in water with the advantages of speed, convenience, sensitivity, low-cost, and freedom from use of toxic organic solvents.

Table 2

Analysis of OCPs in an aqueous CRM sample by using MA–HS-SPME and LLE procedures

Pesticides	LLE (µg/l)	MA–HS-SPME (µg/l)
γ-HCH	6.53 (6.43%)	7.47 (10.7%)
Heptachlor	10.50 (0.35%)	10.62 (8.9%)
Dieldrin	7.44 (6.05%)	8.00 (16.2%)
Endrin	14.68 (9.88%)	17.00 (25.7%)
<i>p,p'</i> -DDT	9.30 (11.8%)	9.07 (34.5%)

Data in parenthesis are RSDs (n=3).

## Acknowledgements

This research was carried out with the financial (90AS-1.2.2-PI-P2(3)) support of the Council of Agriculture (COA) in Taiwan. The authors express their gratitude to Department chair, Ms. Sue-Sun Wong, Miss Chiu-Hua Lin, and Huey-Fen Ju who supported the experimental activity.



## References

- [1] L.L. McConnell, T.F. Bidleman, W.E. Cotham, M.D. Walla, *Environ. Pollut.* 101 (1998) 391.
- [2] T.Y. Ku, 1976. Chlorinated Hydrocarbon Insecticide Residues in the Agriculture Environment of Taiwan Annual Report of Plant Protection Center, Taiwan.
- [3] D. Barcelo, *J. Chromatogr.* 643 (1993) 117.
- [4] N. Masque, R.M. Marce, F. Borrull, *Trends Anal. Chem.* 17 (6) (1998) 384.
- [5] C. Aguilar, F. Borrull, R.M. Marce, *J. Chromatogr. A* 771 (1997) 221.
- [6] B. Zygmunt, *J. High Resolut. Chromatogr.* 20 (1997) 482.
- [7] M.R. Lee, J.S. Lee, W.S. Hsiang, C.M. Chen, *J. Chromatogr. A* 775 (1997) 267.
- [8] J. Slobodnik, A.J.H. Louter, J.J. Vreuls, I. Liska, U.A.Th. Brinkman, *J. Chromatogr. A* 768 (1997) 239.
- [9] J. Pawliszyn, *Solid-Phase Microextraction: Theory and Practice*, Wiley–VCH, New York, 1997.
- [10] R.P. Belardi, J. Pawliszyn, *Water Poll. Res. J. Can.* 24 (1989) 179.
- [11] C.L. Arthur, J. Pawliszyn, *Anal. Chem.* 62 (1990) 2145.
- [12] C.L. Arthur, K. Pratt, S. Motlagh, J. Pawliszyn, R.P. Belardi, *J. High Resolut. Chromatogr.* 15 (1992) 741.
- [13] C. Aguilar, A. Penalver, E. Pocurull, J. Ferre, F. Borrull, R.M. Marce, *J. Chromatogr. A* 844 (1999) 425.
- [14] C. Goncalves, M.F. Alpendurada, *J. Chromatogr. A* 963 (2002) 19.
- [15] C. Goncalves, M.F. Alpendurada, *J. Chromatogr. A* 968 (2002) 177.
- [16] B.A. Tomkins, A.R. Barnard, *J. Chromatogr. A* 964 (2002) 21.
- [17] K.D. Buchholz, J. Pawliszyn, *Environ. Sci. Technol.* 27 (1993) 2844.
- [18] Z. Zhang, J. Pawliszyn, *J. High Resolut. Chromatogr.* 16 (1993) 689.
- [19] F. Guan, K. Watanabe, A. Ishii, H. Seno, T. Kumazawa, H. Hattori, O. Suzuki, *J. Chromatogr. B* 714 (1998) 205.
- [20] M. Yashiki, T. Kojima, T. Miyazaki, N. Nagasawa, Y. Iwasaki, K. Hara, *Forensic Sci. Intern.* 76 (1995) 169.
- [21] R.-A. Doong, P.-L. Liao, *J. Chromatogr. A* 918 (2001) 177.
- [22] A. Zlotorzynski, *Crit. Rev. Anal. Chem.* 25 (1995) 43.
- [23] H.M. Kingston, S.J. Haswell, *J. Am. Chem. Soc.* 119 (1997) 772.
- [24] Q. Jin, F. Liang, H. Zhang, L. Zhao, Y. Huan, D. Song, *Trends Anal. Chem.* 18 (1999) 479.
- [25] H.M. Pylypiw Jr., T.L. Arsenaault, C.M. Thetford, M.J. Incorvia Mattina, *J. Agric. Food Chem.* 45 (1997) 3522.
- [26] C.S. Eskilsson, E. Bjorklund, *J. Chromatogr. A* 902 (2000) 227.
- [27] Y. Wang, M. Bonilla, H.M. McNair, *J. High Resolut. Chromatogr.* 20 (1997) 213.
- [28] F. Hernandez, J. Beltran, F.J. Lopez, J.V. Gaspar, *Anal. Chem.* 72 (2000) 2313.
- [29] W.H. Ho, S.J. Hsieh, *Anal. Chim. Acta* 428 (2001) 111.
- [30] M. Zhu, F.J. Aviles, E.D. Conte, D.W. Miller, P.W. Perschbacher, *J. Chromatogr. A* 833 (1999) 223.
- [31] M.-C. Wei, J.-F. Jen, *Chromatographia* 55 (2002) 701.
- [32] J.-F. Jen, Y.-S. Su, Y.-I. Chen, *J. Chromatogr. A* 976 (2002) 349.
- [33] B. McMahon, N. Hardin, in: 3rd Edition, *Pesticide Analytical Manual*, Vol. 1, US Food and Drug Administration, Washington, DC, 1994, p. 1, Section 302.
- [34] P.A. Frazey, R.M. Barkley, R.E. Sievers, *Anal. Chem.* 70 (1998) 638.